

Description

The BP3315 is a high precision primary-side regulation driver with single stage Active PFC, specially designed for universal input offline flyback or buck-boost constant current LED lighting. The driver with on-chip PFC circuit achieves high power factor and low THD. Operating in critical conduction mode, the power MOSFET switching loss is reduced and the inductor is fully utilized.

The BP3315 adopts proprietary primary side current sensing scheme. It can precisely control the LED current without secondary side sense and feedback circuits. The device integrates a 650V power MOSFET to further reduce external components, for saving cost and PCB area.

The BP3315 utilizes patented line and load voltage compensation method to achieve excellent line and load regulation.

The BP3315 offers rich protection functions to improve the system reliability, including LED open circuit protection, LED short circuit protection, VCC over voltage protection, VCC under voltage protection, CS resistor open protection and cycle by cycle current limit. All the protection functions are auto-recovery. The system reliability is further improved by the thermal regulation function. The output current is reduced when the driver is over temperature.

Typical Application

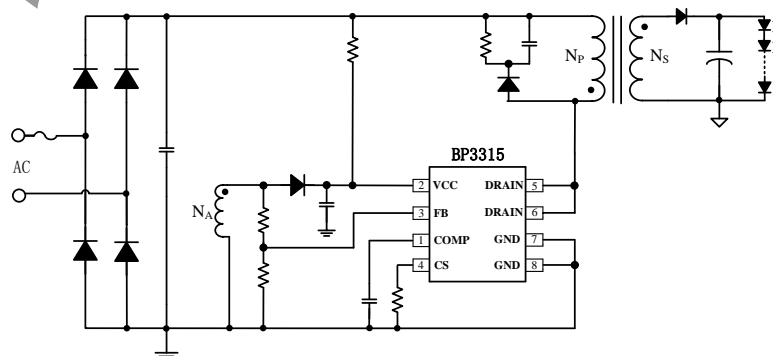

Figure 1. Typical application circuit for BP3315

Features

- Single-Stage Active PFC for High Power Factor and Low THD
- Primary Side Control Constant Current Operation, No Opto-Coupler required
- Integrated 650V Power MOSFET
- $\pm 3\%$ LED Current Accuracy
- Excellent Line and Load Regulation
- Critical Conduction Mode Operation
- Ultra-Low (33uA) Startup Current
- High Resistance Feedback Resistor for Improved Efficiency
- LED Open and Short Circuit Protection
- CS Resistor Open Circuit Protection
- Cycle-by-Cycle Current Limit
- VCC Over-voltage and Under-voltage Protection
- Auto Fault Recovery
- Thermal Regulation Function
- Available in SOP8 package

Applications

- E27/ GU10 LED Bulb, Spot Light
- PAR30, PAR38 LED Lamp
- T8/T10 LED String
- Other LED Lighting

Ordering Information

Part Number	Package	Operating Temperature	Packing Method	Marking
BP3315	SOP8	-40 °C to 105 °C	Tape 4,000 Piece/Reel	BP3315 XXXXXY WXY

Pin Configuration and Marking Information

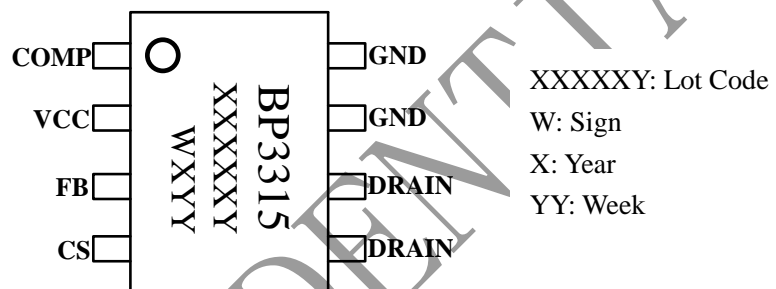

Figure 2. Pin configuration

Pin Definition

Pin No.	Name	Description
1	COMP	Loop Compensation Node. This pin connects a capacitor to GND for stabilization of the control loop, achieving accurate LED current, high Power Factor and low THD.
2	VCC	Power Supply Pin. Connect a bypass capacitor from this pin to GND.
3	FB	Feedback Voltage Input Pin. This pin detects the transformer demagnetization signal and the output voltage.
4	CS	Current Sense Pin. Connect a resistor to GND to sense the power MOSFET current.
5,6	DRAIN	Internal HV Power MOSFET Drain.
7,8	GND	Ground.

Absolute Maximum Ratings (note1)

Symbol	Parameters	Range	Units
V _{DS}	Internal HV MOSFET Drain to Source voltage	-0.3~650	V
V _{CC}	VCC pin input voltage	-0.3~25	V
I _{CC_MAX}	VCC pin maximum sink current	5	mA
COMP	Compensation pin voltage	-0.3~6	V
FB	Feedback pin input voltage	-0.3~6	V
CS	Current sense pin input voltage	-0.3~6	V
P _{DMAX}	Power dissipation (note2)	0.45	W
θ _{JA}	Thermal resistance (Junction to Ambient)	145	°C/W
T _J	Operating junction temperature	-40 to 150	°C
T _{STG}	Storage temperature range	-55 to 150	°C
	ESD (note3)	2	kV

Note 1: Stresses beyond those listed under “absolute maximum ratings” may cause permanent damage to the device. Under “recommended operating conditions” the device operation is assured, but some particular parameter may not be achieved. The electrical characteristics table defines the operation range of the device, the electrical characteristics is assured on DC and AC voltage by test program. For the parameters without minimum and maximum value in the EC table, the typical value defines the operation range, the accuracy is not guaranteed by spec.

Note 2: The maximum power dissipation decrease if temperature rise, it is decided by T_{JMAX}, θ_{JA}, and environment temperature (T_A). The maximum power dissipation is the lower one between P_{DMAX} = (T_{JMAX} - T_A)/θ_{JA} and the number listed in the maximum table.

Note 3: Human Body mode, 100pF capacitor discharge on 1.5kΩ resistor

Recommended Operation Conditions

Symbol	Parameter	Range	Unit
V _{CC}	Power supply voltage	8.5 ~ 18	V
P _{OUT1}	Output power (Input voltage 230V ±15%)	< 10	W
P _{OUT2}	Output power (Input voltage 85V~265V)	< 7	W

Electrical Characteristics (Notes 4, 5) (Unless otherwise specified, $V_{CC}=15V$ and $T_A=25^\circ C$)

Symbol	Parameter	Conditions	Min	Typ	Max	Units
Supply Voltage Section						
V_{CC_ON}	V_{CC} Turn On Threshold	V_{CC} Rising		16.7		V
V_{CC_UVLO}	V_{CC} Turn Off Threshold	V_{CC} Falling		7.5		V
V_{CC_OVP}	V_{CC} Over Voltage Protection threshold			19		V
V_{CC_CLAMP}	V_{CC} Clamp Voltage			23		V
I_{CC_UVLO}	V_{CC} Startup Current	V_{CC} Rising $V_{CC}=V_{CC_ON}-1V$		33	50	uA
I_{CC}	V_{CC} Operating Current	$F_{OP}=10kHz$		0.5	1	mA
Feedback Section						
V_{FB_FALL}	FB Falling Edge Threshold Voltage	FB Falling		0.1		V
V_{FB_HYS}	FB Hysteresis Voltage	FB Rising		0.08		V
V_{FB_OVP}	FB Over Voltage Protection Threshold			1.6		V
T_{ON_MAX}	Maximum On Time			25		us
T_{OFF_MIN}	Minimum Off Time			4.5		us
T_{OFF_MAX}	Maximum Off Time			100		us
Current Sense Section						
V_{CS_LIMIT}	CS Peak Voltage Limitation			1.0		V
T_{LEB_CS}	Leading Edge Blanking Time for Current Sense			350		ns
T_{DELAY}	Switch off Delay Time			200		ns
Compensation Section						
V_{REF}	Internal Reference Voltage		0.194	0.200	0.206	V
V_{COMP_LO}	COMP Low Clamp Voltage			1.5		V
Symbol	Parameter	Conditions	Min	Typ	Max	Units



BP3315

晶丰明源半导体

PSR Single-Stage APFC Offline LED Driver

V_{COMP}	COMP Linear Operating Voltage Range		1.5		3.5	V
V_{COMP_OVP}	COMP Protection Threshold			3.6		V
Power MOSFET Section						
R_{DS_ON}	Static Drain-source On-resistance	$V_{GS}=10V/I_{DS}=1A$		4.2		Ω
BV_{DSS}	Drain-Source Breakdown Voltage	$V_{GS}=0V/I_{DS}=250\mu A$	650			V
I_{DSS}	Power MOSFET Drain Leakage Current	$V_{GS}=0V/V_{DS}=650V$			1	μA
Thermal Regulation Section						
T_{REG}	Thermal Regulation Temperature			150		$^{\circ}C$

Note 4: production testing of the chip is performed at 25 $^{\circ}C$.

Note 5: the maximum and minimum parameters specified are guaranteed by test, the typical value are guaranteed by design, characterization and statistical analysis

BPS

CONFIDENTIAL

Internal Block Diagram

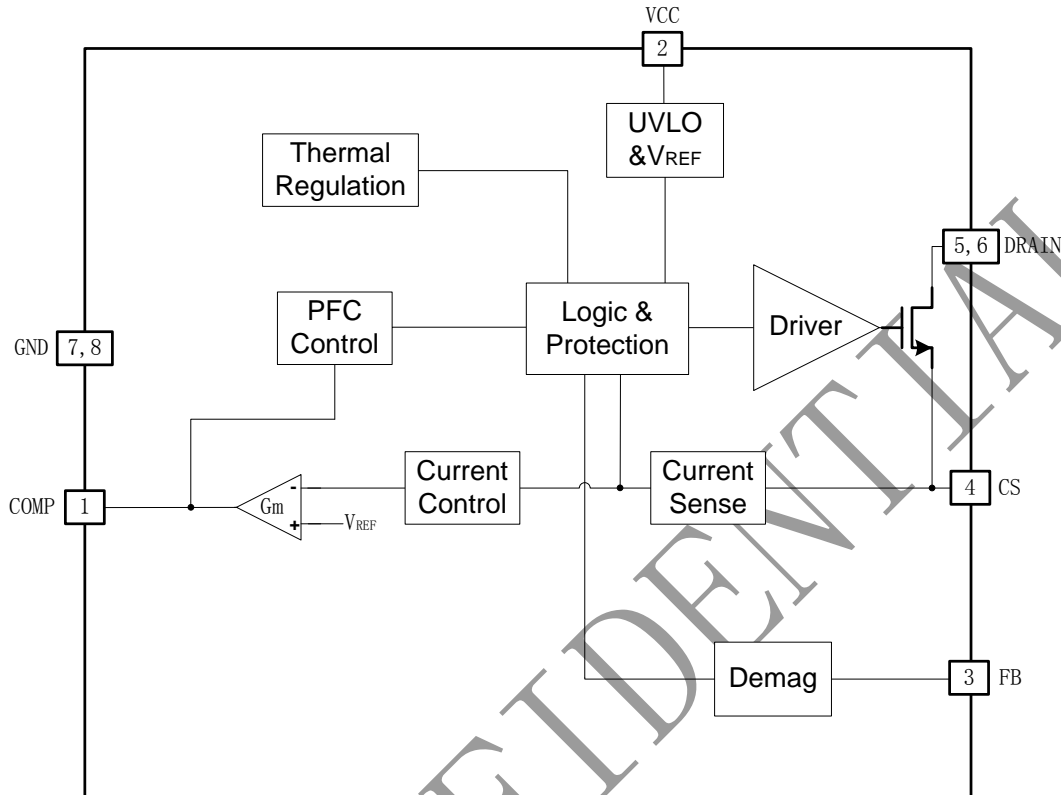

Figure 3. BP3315 Internal Block Diagram

Application Information

The BP3315 is a high precision primary-side regulation single stage Active PFC driver integrating 650V power MOSFET, specially designed for constant current LED lighting. Operating in critical conduction mode, the driver achieves high power factor, low THD and high efficiency.

1 Start Up

After system powered up, the VCC pin capacitor is charged up by the start up resistor. When the VCC pin voltage reaches the turn on threshold, the internal circuits start working, the COMP pin voltage is pulled up to 1.5V quickly, and then the BP3315 starts switching. The system works at 10kHz frequency at the beginning, the COMP voltage rises up gradually, and the transformer primary peak current also rises up. The LED current hence achieves a soft start without overshoot. After the output voltage is built

up, the VCC power is supplied by the auxiliary winding.

2 Constant Current Control

The BP3315 adopts proprietary primary side current sensing scheme. It can precisely control the LED current without secondary side sense and feedback circuit.

The current in LED can be calculated by the equation:

$$I_{OUT} \approx \frac{V_{REF}}{2 \times R_{CS}} \times \frac{N_P}{N_S}$$

Where,

V_{REF} : Internal reference voltage

N_P : Primary winding turns of transformer

N_S : Secondary winding turns of transformer



Res: The current sensing resistor value

3 Feedback Network

The BP3315 senses the output current zero crossing information through the feedback network, the FB falling threshold voltage is set to 0.1V with 0.08V hysteresis. The FB pin is also used to detect output OVP, the threshold voltage is 1.6V. The ratio of FB upper resistor to lower resistor can be set as:

$$\frac{R_{FBL}}{R_{FBL} + R_{FBH}} = \frac{1.6V}{V_{OVP_FB}} \times \frac{N_S}{N_A}$$

Where,

R_{FBL} : The lower resistor of the feedback network

R_{FBH} : The upper resistor of the feedback network

V_{OVP_FB} : Output over voltage setting point

N_S : Secondary winding turns of transformer

N_A : Auxiliary winding turns of transformer

The FB upper resistor can be set to around 330K Ω to improve the system efficiency. It is also used for fine tuning the LED current line compensation.

4 Thermal Regulation

The BP3315 integrates thermal regulation function. When the system is over temperature, the output current is gradually reduced; the output power and thermal dissipation are also reduced. The system temperature is regulated and the system reliability is improved. The thermal regulation temperature is set to 150 $^{\circ}$ C internally.

5 Protection Functions

The BP3315 offers rich protection functions to improve the system reliability.

When the LED is open circuit, the output voltage will gradually rise up. The V_{CC} voltage will also rise up. When V_{CC} voltage reaches the 19V OVP threshold, it will trigger fault logic and the system stops switching. At some catastrophic fault condition, if the V_{CC} voltage continues to rise, the internal clamping circuit will limit the V_{CC} voltage to 23V,

which helps improving the system reliability.

When the LED is shorted circuit, the system will work under 10kHz switching frequency. Meanwhile, the output voltage is low and the auxiliary winding cannot charge the VCC pin. So the VCC pin voltage will gradually decrease and finally reaches the UVLO threshold.

After the system enters into fault condition, the VCC voltage will decrease until it reaches UVLO threshold, then the system will re-start again. If the fault condition is removed, the system will resume normal operation.

When the output is short circuit or the transformer is saturated, the CS peak voltage will be relatively high. When CS voltage reaches the internal limitation (1V), the power MOSFET will be turned off instantaneously. This cycle by cycle current limitation can help protecting the power MOSFET, the transformer and the output rectifying diode.

6 PCB Layouts

The following guidelines should be followed in BP3315 PCB layout:

Bypass Capacitor

The bypass capacitor on VCC pin should be as close as possible to the VCC and GND pins.

Ground Path

The power ground path for current sense resistor should be short and wide, and it should be as close as possible to the IC ground (pin 7&8), otherwise the LED output current accuracy maybe affected. The IC signal ground for COMP and FB components should be connected to the IC GND pin with short traces and should be away from the power ground path.

The Area of Power Loop

The area of main current loop should be as small as possible to reduce EMI radiation, such as the primary current loop, the snubber circuit and the secondary rectifying loop.



晶丰明源半导体

BP3315

PSR Single-Stage APFC Offline LED Driver

FB Pin

The feedback resistor divider should be as close as possible to the FB pin, and the trace must keep away from dynamic node of the transformer (DRAIN pin trace), otherwise the FB pin OVP function might have risk to be mis-triggered by the system noise.

DRAIN Pin

To increase the copper area of DRAIN pin for better thermal dissipation. However too large copper area may compromise EMI performance.

BPS CONFIDENTIAL

Physical Dimensions

